

EA009

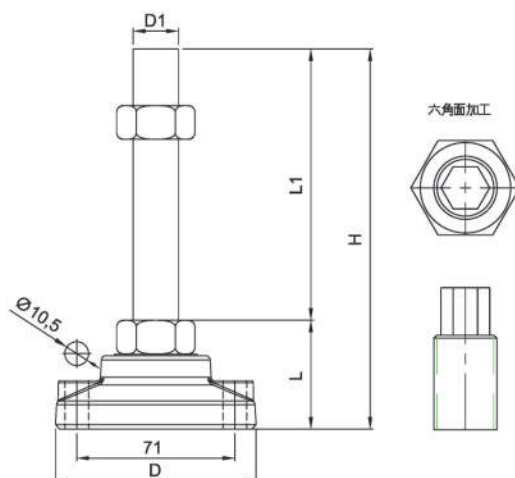

ZA009



- *底座有壁虎孔。
- *底座為鋁合金一體成型。
- *外觀拋光鍍鉻處理，導電性佳。
- *適用在無塵室設備，鋁擠型設備，高載重機械設備。
- *牙端可做六面加工。

產品型號 Part No.	螺絲材料 Screw Material	底盤直徑 D mm	底盤高度 L mm	螺絲規格 D1 mm	螺絲長度 L1 mm	總高 H mm	荷重 kg
EA009-90-16-100	SUS304 Stainless	90	47	M16*P2.0	100	147	1500
EA009-90-16-150			47	M16*P2.0	150	197	1500
EA009-90-16-200			47	M16*P2.0	200	247	1500
EA009-90-20-100			50	M20*P2.5	100	150	2000
EA009-90-20-150			50	M20*P2.5	150	200	2000
EA009-90-20-200			50	M20*P2.5	200	250	2000
ZA009-90-16-100	SS41 Zinc	90	44	M16*P2.0	100	144	1000
ZA009-90-16-150			44	M16*P2.0	150	194	1000
ZA009-90-16-200			44	M16*P2.0	200	244	1000
ZA009-90-20-100			46	M20*P2.5	100	146	1500
ZA009-90-20-150			46	M20*P2.5	150	196	1500
ZA009-90-20-200			46	M20*P2.5	200	246	1500
ZA009-90-24-100			52	M24*P3.0	100	152	2000
ZA009-90-24-150			52	M24*P3.0	150	202	2000
ZA009-90-24-200			52	M24*P3.0	200	252	2000
ZA009-90-30-110			55	M30*P3.5	110	165	2500
ZA009-90-30-150			55	M30*P3.5	150	205	2500